

WE ARE GLASS PEOPLE

5 1/2" DG SPEEDLINE

HiPERFORM

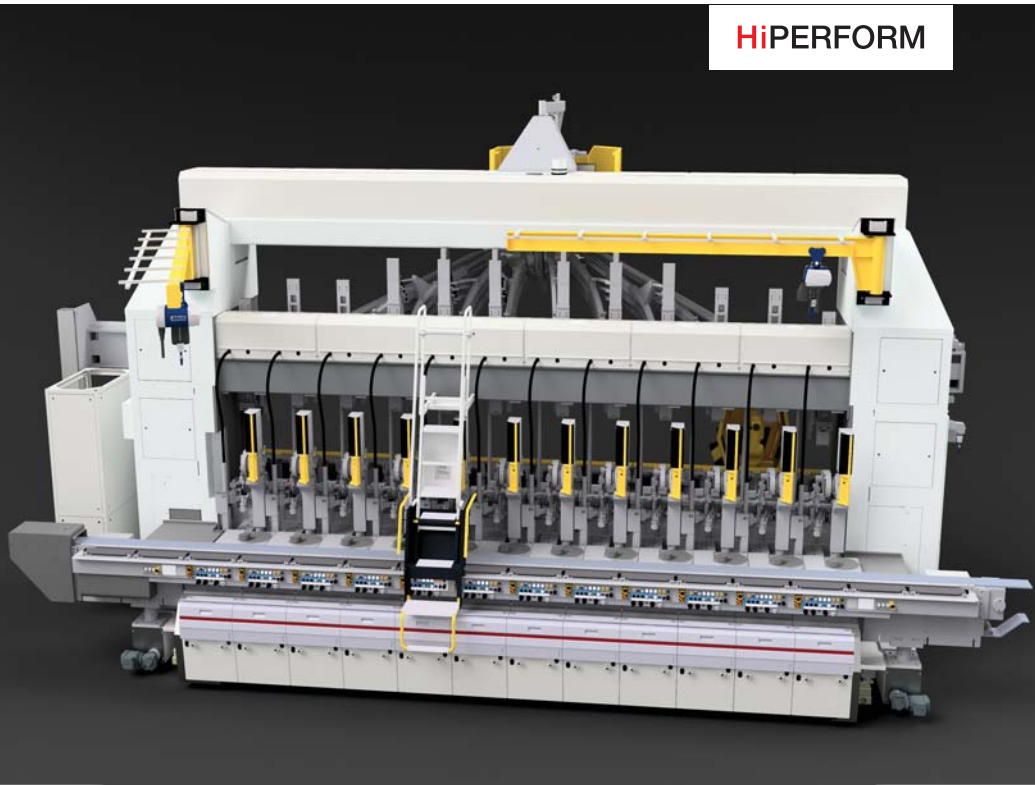

h heye
international

IS-MACHINE MANUFACTURING PROGRAMME

The high-performance 5 ½" DG Heye SpeedLine IS-Machine is available for up to 24 sections.

According to the customers' needs the machine can either be utilised for Blow & Blow, Press & Blow or for NNPB.

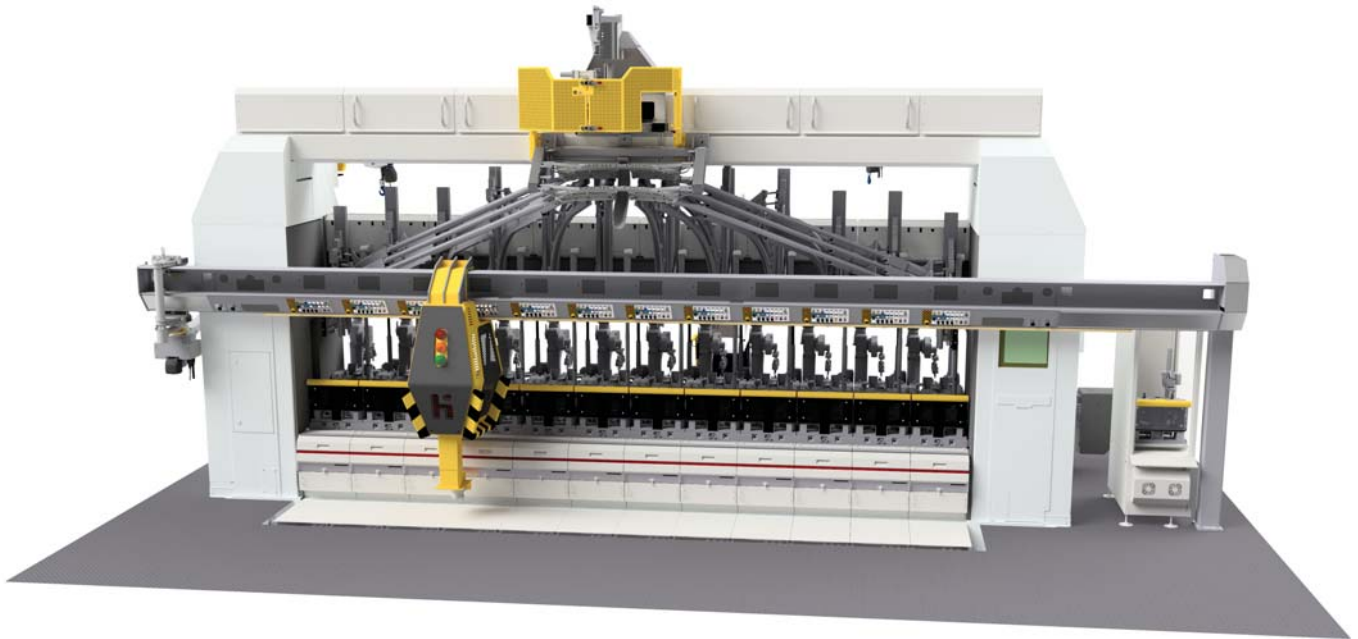

OVERVIEW

Advantages

- Available for up to 24 sections
- Applicable for B&B, P&B and NNPB
- High-performance
- High-speed
- Reproducible motion patterns, especially in connection with Heye servo components (e.g. Heye Servo Invert, Servo Takeout, Servo Pushers)
- Lightweight and high-quality products can be produced
- Applicable even for widemouth articles
- Process supervision easily possible by integrating the Heye Process Control

Emissions

- The A-weighted permanent sound pressure level in connection with all components integrated in the machine is >85 dB(A)

Available machine sizes

Single IS-Machines

- 6 sections
- 8 sections
- 10 sections
- 12 sections

Tandem IS-Machines

- 12 sections
- 16 sections
- 20 sections
- 24 sections

Colour

- Standard colour RAL 9010 white, glossy (other colours on request)

DIMENSIONS

Heye SpeedLine IS-Machines 5 1/2" DG

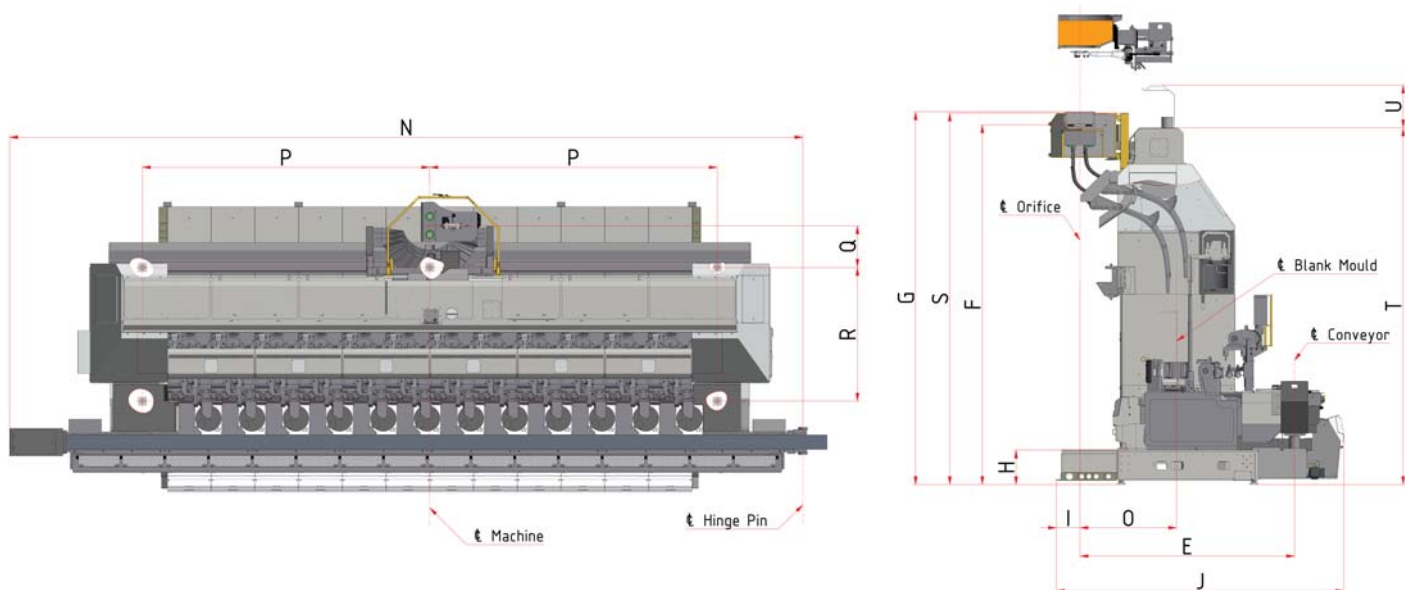

Depending on the equipment the dimensions can vary:

| | | IS 6 Sec. | IS 8 Sec. | IS 10 Sec. | IS 12 Sec. |
|-----------------------------------|---|---------------------|-----------|------------|------------|
| CL offset conveyor | E | 2566 mm ±15 mm*1 | | | |
| Top of funnel | F | 4238 mm*2 / 4438 mm | | | 4438 mm |
| Gob interceptor height | G | 4411 mm*2 / 4611 mm | | | 4611 mm |
| Height of bed | H | 425 mm | | | |
| Distance bed to orifice | I | 328 mm | | | |
| Total width | J | 3516 mm | | | |
| Total length | N | 6571 mm | 7638 mm | 8705 mm | 9772 mm |
| Offset | O | 1168 mm | | | |
| Machine foot position (6 feet) | P | 1905 mm | 2438 mm | 2972 mm | 3505 mm |
| | Q | 470 mm | | | |
| | R | 1630 mm | | | |
| Top edge protection grid | S | 4371 mm*2 / 4571 mm | | | 4571 mm |
| Top of scoop beam | T | 4186 mm*2 / 4386 mm | | | 4386 mm |
| Opened flap of scoop beam | U | 533 mm | | | |

*1 Depending on selected pusher type

*2 Reduced in height

SERVICE REQUIREMENTS

The values stated refer to a 5 1/2" DG IS-Machine

| APPLICATION | PRESSURE | | CONSUMPTION PER SECTION |
|---|-------------|-----------|-------------------------|
| | PSI | bar | Nm³/h |
| Low pressure operating air | 31.5 | 2.2 | 110 |
| High pressure operating air BB | 43.5 | 3.0 | 130 |
| High pressure operating air NNPB | 43.5 | 3.0 | 165 |
| Pilot air | 50 - 58 | 3.5 - 4.0 | 6 |
| Pusher | 29.0 - 72.5 | 2.0 - 5.0 | 6 |
| Vacuum blow mould | 12.3 | 0.845 | 66 |
| Cooling air, dead plate and machine conveyor | 1.16 | 0.08 | 1200 |
| Cooling air: | | | |
| Blank side radial stack cooling / HiFlow Blow side radial cooling | 1.45 | 0.1 | 6000 |
| Blank side radial cooling NNPB Blow side radial cooling | 1.45 | 0.1 | 5300 |
| Blank side radial stack cooling / HiFlow Blow side axial cooling | 2.32 | 0.16 | 3800 |
| Blank side radial stack cooling / HiFlow Blow side Vertical Air Stream (VAS) | 2.32 | 0.16 | 4100 |
| Blank side radial cooling NNPB Blow side axial cooling | 2.90 | 0.2 | 2000 |
| Blank side radial cooling NNPB Blow side Vertical Air Stream (VAS) | 2.61 | 0.18 | 2200 |
| Blank side axial cooling Blow side axial cooling | 2.90 | 0.2 | 2000 |
| Blank side axial cooling Blow side Vertical Air Stream (VAS) | 2.61 | 0.18 | 2200 |
| Cooling water | 36.2 - 72.5 | 2.5 - 5.0 | 0.6 - 0.9 |

PRODUCTION LIMIT TABLE

| | PROCESS | | |
|---|---------|--------|--------|
| | B&B | P&B | NNPB |
| A max. body diameter (Stack, w/o Vacuum) | 111 mm | | |
| A max. body diameter (VAS) | 102 mm | | |
| A max. body diameter (Axial Cooling) | 96 mm | | |
| H max. height (under finish, VAS cooling) | 343 mm | 300 mm | 326 mm |
| H min. height (under finish, VAS cooling) | 115 mm | 82 mm | 106 mm |
| B max. finish diameter | 48 mm | 90 mm | 48 mm |

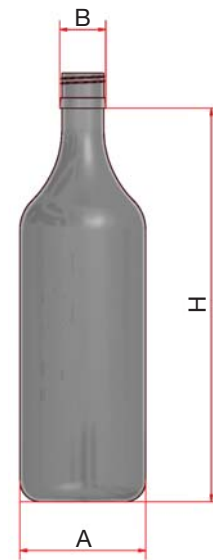

- Operating air supply must be clean, dry and oil-free
- Operating air with constant pressure ± 0.02 bar (0.3 psi)
- Pilot air min. 0.5 bar (7.2 psi) in excess of operating air
- Pilot air must be dry, clean and filtered by a microfog oiler at a constant pressure of ± 0.02 bar (0.3 psi)
- Maximum temperature of compressed air 45°C
- Water hardness not more than 6°dH (1°dH acc. to 0.1783 mmol/l HCO³)
- Air of mould cooling must be clean and oil-free
- Maximum temperature of cc-oil 50°C

Illustrations are non-binding and may include optional equipment. Products are subject to continuous technical modifications.

1018/Web

Heye International GmbH
Lohplatz 1, 31683 Obernkirchen
Germany

T +49 5724 26 26-0
F +49 5724 26 229

www.heye-international.com

